

enough for a large convolution function! Where the FPGA design uses Block RAM for other functions, it then becomes interesting to use hardware like the HERON-FPGA5 where the image can be stored in off-chip SDRAM.

Conclusions

Many of the key imaging functions break down into highly repetitive tasks that are well suited to modern FPGAs, especially those with built-in hardware multipliers and on-chip RAM. The remaining tasks require hardware more suited to control flows and decision making such as DSPs. To gain the full benefit of both approaches systems are required that can effectively combine both FPGAs and DSPs.

The next logical step beyond this is the addition to the HERON module range of devices such as the Virtex-II Pro series from Xilinx. With a processor core in the form of the PowerPC, a sea-of-gates, built-in multipliers and on-chip RAM, a self-contained high performance imaging solution becomes possible in a single chip. For more information keep an eye on www.hunteng.co.uk where new information will be added as it becomes available.



Richard Williams joined Hunt Engineering in 1994 and is a hardware engineer developing FPGA modules for HERON systems

A DSP-based electricity metering system

by Jeroen Van den Keybus, Geert Deconinck, Koen Vanthournout, Johan Driesen, Ronnie Belmans - K.U.Leuven, ESAT



A DSP-based electricity metering system



A DSP-based electricity metering system

Electrical energy distribution is undergoing important changes. Electricity markets are currently opening up in the United States and the European Union, enabling industry and customers to choose their energy supplier freely. The associated registration and billing infrastructure ('metering') becomes increasingly complicated, often including facilities for user interaction as well.

Electrical energy production is no

longer centralized in large scale power plants. Medium sized Combined Heat and Power production units are commonly used in industry, wind energy production is no longer negligible and small scale solar energy production is slowly finding its way into office buildings and homes. Consumers now also produce and this may happen anywhere in the distribution system.

Nearly all electronic industrial, office and consumer equipment injects harmonic, non-sinusoidal currents into the grid, forcing

- CONTENTS
- ARTICLES
- NEWS
- ALGORITHMS
- REVIEWS
- NEW PRODUCTS
- EVENTS
- COMPANIES
- JOBS
- INFO

1
2
3
4
5
6
7
8
9
10
11
12
13
14
15
16
17

electricity distributors to derate their transformers and cables. Consequently, the operational limits of this equipment are lowered. Additionally, in a competitive environment, the grid is often exploited near to its maximum rating and an outage is much more likely to happen. The reliability of the energy supply is extremely important and depends on the accurate estimation of the real grid load.

Electronic equipment is also prone to short term voltage disturbances, which are often caused by incidents in the grid or at another customer's site. Brief voltage dips or surges can lead to large production downtime. Every disturbance must be detected and accurately charted in order to indicate the cause and realm of these 'power quality' problems.

New requirements for metering systems.

Clearly, metering systems are a key element in the new electricity market (Figure 1). They accurately measure energy consumption, even when the load current is distorted. Whenever a customer changes supplier, Automated Meter Reading (AMR) allows the accumulated amount of energy to be quickly transmitted to the supplier. The captured current data can also be used locally to control active power conditioning devices, so to improve the power quality.

The information is not centralized,

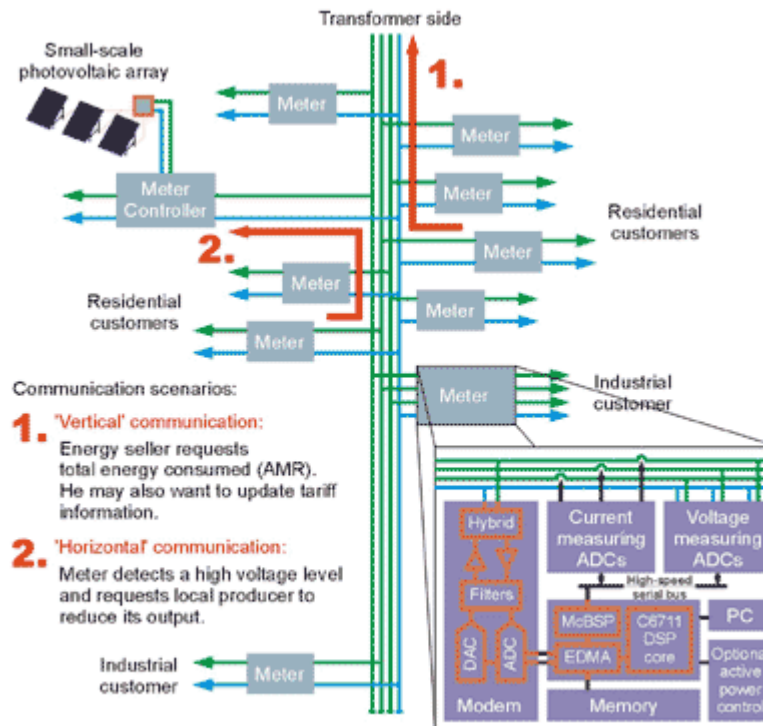

Figure 1: Block Diagram for DSP based Meter Reading Systems

but instead it is conveyed only between the interested parties. The result is a distributed system with increased reliability level.

The remainder of this article focuses on the implementation of a prototype platform for quick implementation of a metering system in a low voltage distribution grid. It uses both traditional and new power definitions to calculate power consumption, employs Power Line Communication (PLC) as a communications channel and, by

adding an FPGA (Field Programmable Gate Array), controls an active power filter to maximize grid capacity. It is based on the Texas Instruments (TI) TMS320C6711 Development Starter Kit (DSK), making it a cost-effective solution as well.

Power measurement

Measuring electrical power is straightforward: seven TI ADS7818 analog to digital converters (ADCs) measure current and voltage synchronously

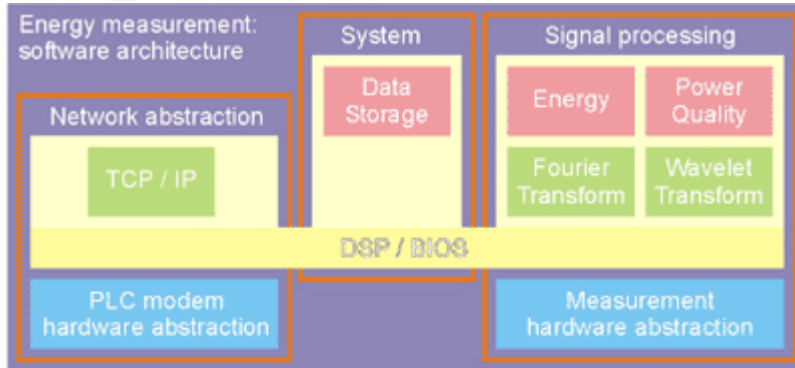

Figure 2: Algorithm Structure for DSP Meter Reading System

at 19.2 kHz, and transmit serial data across an isolation barrier using optocouplers, protecting both equipment and engineers from hazardous mains voltages.

The 'C6711 Multichannel Buffered Serial Port (McBSP), combined with its Enhanced Direct Memory Access (EDMA) controller, reads the data into memory in the background. An eXpress DSP compliant low level I/O driver, together with DSP/BIOS, minimizes software overhead and allows our researchers to focus on their job: evaluating new power measurement techniques. Built-in DSP/BIOS stacking serial I/O drivers allow them to shape samples exactly the way their algorithms require it.

New measurement techniques are important. When currents and even voltages become non-sinusoidal, active power is not longer an accurate measure of the grid load, which is, besides the actual energy cost, exactly what a

customer needs to be charged for. Most power existing calculations use the Fourier transform to obtain the harmonic content of the signal. New techniques, based on wavelets and adaptive filters, are currently investigated. Clearly, powerful 'C6711 floating-point DSPs are the ideal target to evaluate these math-intensive algorithms in real-time (Figure 2.).

Disturbance detection

Disturbances in the grid often go unnoticed. Others may upset or even damage sensitive equipment. Light intensity variations due to irregular small voltage changes, also known as flicker, have shown to be extremely irritating to humans. It is expected that limits on these phenomena will be included in future electrical energy delivery contracts and meters must therefore detect and classify these 'power quality' related events.

Solutions range from simple

PW DSP SALE!

TI TMS320, Motorola 56k
Analog Devices SHARC, Floating Point & Fixed Point Systems

We have a number of high quality DSP Development Systems for sale.

These are going for ridiculous knock down low prices.

For further information please visit our web site:

www.PATENWorks.com/DSPSale

CONTENTS	1
ARTICLES	2
	3
	4
NEWS	5
	6
	7
ALGORITHMS	8
	9
	10
	11
	12
REVIEWS	13
	14
	15
	16
	17
NEW PRODUCTS	
EVENTS	
COMPANIES	
JOBS	
INFO	

threshold crossing detectors to expert systems and neural networks. Again, the general purpose 'C6711 DSP is well adapted to execute these algorithms.

Communications

A computer connected to the DSK allows TCP/IP based communication using available physical media such as cable TV, wireless, Ethernet, and ADSL. Alternatively, a PLC modem, implemented on a DSK daughtercard, uses the power cables themselves as a transmission channel and decreases the setup cost of the network significantly. High-speed signal processing is required to compensate for errors originating from noisy power lines.

The modem uses the frequency range of 60-400 kHz, allowing the use of a modified ADSL front-end. The THS6002 driver/receiver is capable of injecting a sufficiently strong signal into the grid. It is driven by a THS5671A digital to analog converter (DAC). The receiving part sends the signal to a THS1408 ADC. A small transformer and a number of filters make sure that the modem is well isolated from the power grid. The ADC and DAC are accessible by the EDMA to support sample rates up to 2.1 MHz.

Building the network

Communications are the backbone of intelligent electric power

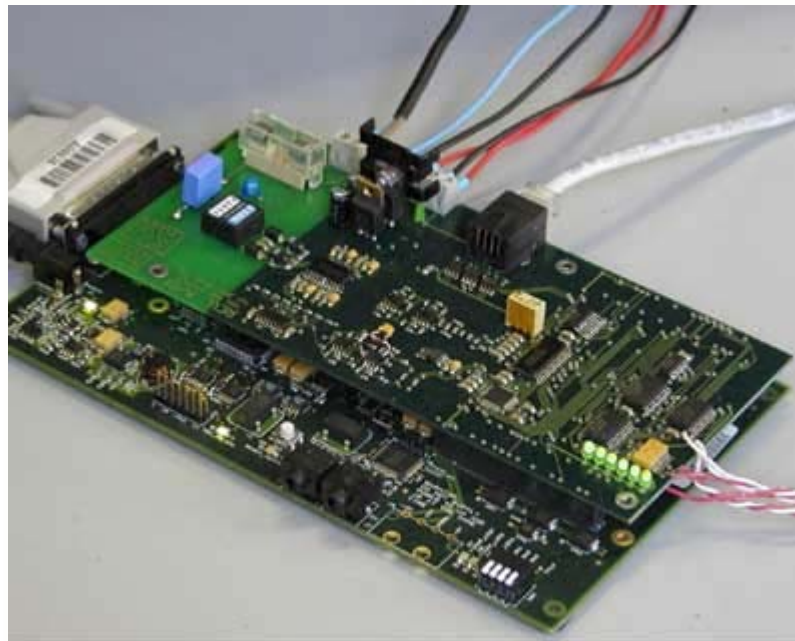

Figure 3: The platform: 'C6711 DSK with PLC daughtercard and high-speed serial measurement connection

networks (Figure 1). In general, the grid's structure changes continuously and other intelligent appliances may show up and disappear as well. Software agents, running on a particular appliance – usually the meter – periodically scan their environment and make and break connections.

When PLC is used, the last meters on the section do not always have sufficient power to reach the first ones, and the software agents must provide a relaying mechanism. Heartbeat signals are used to verify the status of each node. The network driver software

shields these complex tasks from the application programmer and presents a clean, transparent interface. The distributed approach offers graceful degradation in the event of faults and subsequent recovery and reintegration.

Controlling power

Especially when small-scale generators are present, control of generated and consumed power in distribution grids is beneficial to guarantee voltage stability and flatness of load towards the high-voltage distribution grid. Harmonic current data may be used by generators with electronic front-



end to deliberately inject counter-harmonics and optimize the local grid usage. Both applications depend heavily on information exchanged across the network.

Conclusion

Future electrical distribution systems will not only carry energy, but also information concerning tariffs, energy consumption and power quality. This information is gathered from advanced electronic meters, for which a DSP based prototype platform is developed as shown in figure 3. This platform supports a large-scale research program of the Katholieke Universiteit Leuven, Belgium on metering requirements in a liberalized electricity market.

A 'C6711 DSP is used to support advanced power measuring algorithms, power line communication and active power control. The use of eXpress DSP compliant algorithms facilitates the migration towards a low-cost 'C54 DSP, an obvious choice for a practical implementation due to

the huge market volume and high cost sensitivity of this application. The low cost of the 'C6711 DSK allows real-time evaluation of the system in a network. The DSP/BIOS operating system allows power measurement, disturbance detection, active control and PLC to be executed in parallel.

Acknowledgements

This project has been supported by the Texas Instruments ELITE University program.

 If you would like your project to be published in GlobalDSP, please send us a copy for review.

CONTENTS	1
ARTICLES	2
	3
	4
NEWS	5
	6
	7
	8
ALGORITHMS	9
	10
	11
	12
REVIEWS	13
	14
	15
	16
NEW PRODUCTS	17
EVENTS	
COMPANIES	
JOBBS	
INFO	

Reach over 15,000 DSP Engineers and Managers with a product announcement in the DSPStore e-Newsletter

call Chloe on +44 (0)1225 723 349 or email chloe@dspstore.com